



Installation & Operating Instructions

Baker's Oven



Keep instructions in a safe place for future reference

*Glen Dimplex New Zealand Ltd reserves the right to change specifications, the content of this manual or the design of its product without prior notice.

INTRODUCTION

Thank you for purchasing a Nectre Baker's Oven. The Baker's Oven combines a wood-fueled heater with an oven and cooktop. The oven will cook anything from crispy bread to succulent roasts. The cooktop takes four large saucepans and features two removable rings for wok-style cooking.

Best of all, Baker's Oven will spread warmth throughout your kitchen and living area while it cooks.

INSTALLATION

Firstly, check the local building and heating regulations. Different councils in New Zealand have varying regulations about the installation and operation of wood-fired cooking appliances, and you and your installer should be aware of these.

POSITIONING THE NECTRE

The clearances from the appliance to combustible materials must not be less than the following:-

- Rear 125mm
- Side 350mm

If the appliance is placed in the corner of a room, the minimum clearance from the corner edge of the appliance to the nearest combustible surface is 350mm. Refer technical specification document for detailed dimensions.

The diagram below shows the minimum clearances to adjacent walls for parallel installation: the minimum hearth dimensions (750mm x 973mm), and the dimensions of the Bakers Oven.

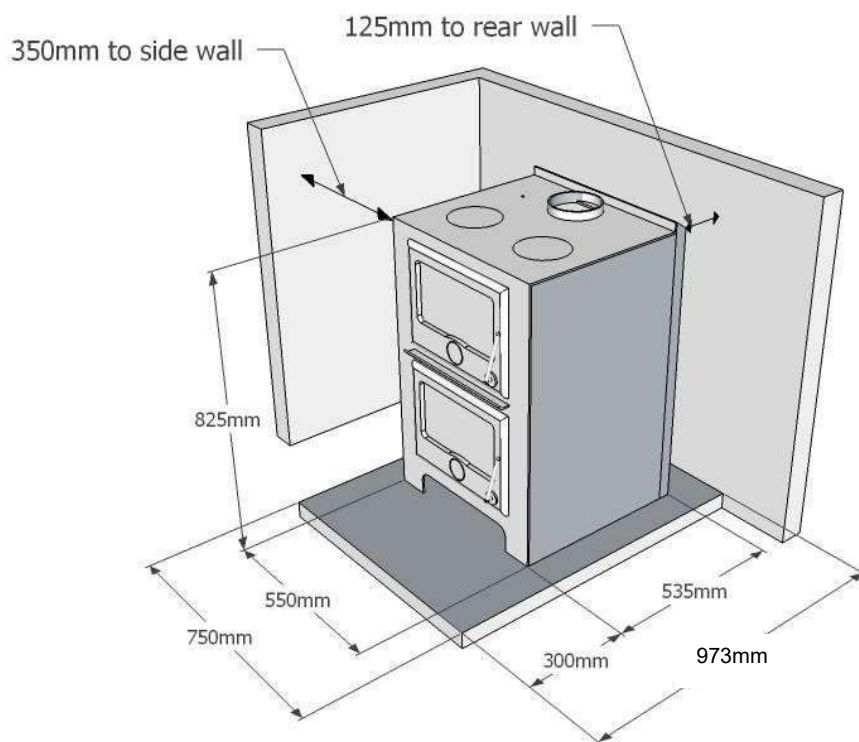

CONSTRUCTING THE FLUE

The Nectre Bakers Oven must be installed with a standard 4.2M long Masport flue system with a dropbox or flue system with a dropbox that has been tested and comply with AS/NZS 2918:2001, Appendix F. Also, the main flue pipe should be fitted with a 900mm long 180° arc or 900mm long Masport stainless steel double flue shield.

The flue kit should be made of stainless steel or vitreous enameled steel, and it shall extend not less than 4.6m above the top of the floor protector and meets the requirements of AS2918/2001. The length will depend on ceiling height and roof design, but the top of the flue pipe must be a minimum of 600mm above the ridge of the roof if the flue penetrates the roof within 3m of the ridge. Or to be of sufficient height to be 3m from the roofline horizontally, but a minimum height of 1m.

If the draft is insufficient or periodic down drafting occurs, and the appliance smokes or only burns slowly, extending the flue or fitting a specialised cowl will usually cure it.

Where the flue penetrates the ceiling and roof, it must comply with AS2918:2001. If the baker's oven is fitted to an existing chimney, ensure that it is sealed at the base of the chimney with a register plate and fit the flue pipe up through the plate and continue until it terminates outside the chimney in accordance with AS2918:2001 4.9.1.

The flue kit must be installed according to the manufacturer's instructions.

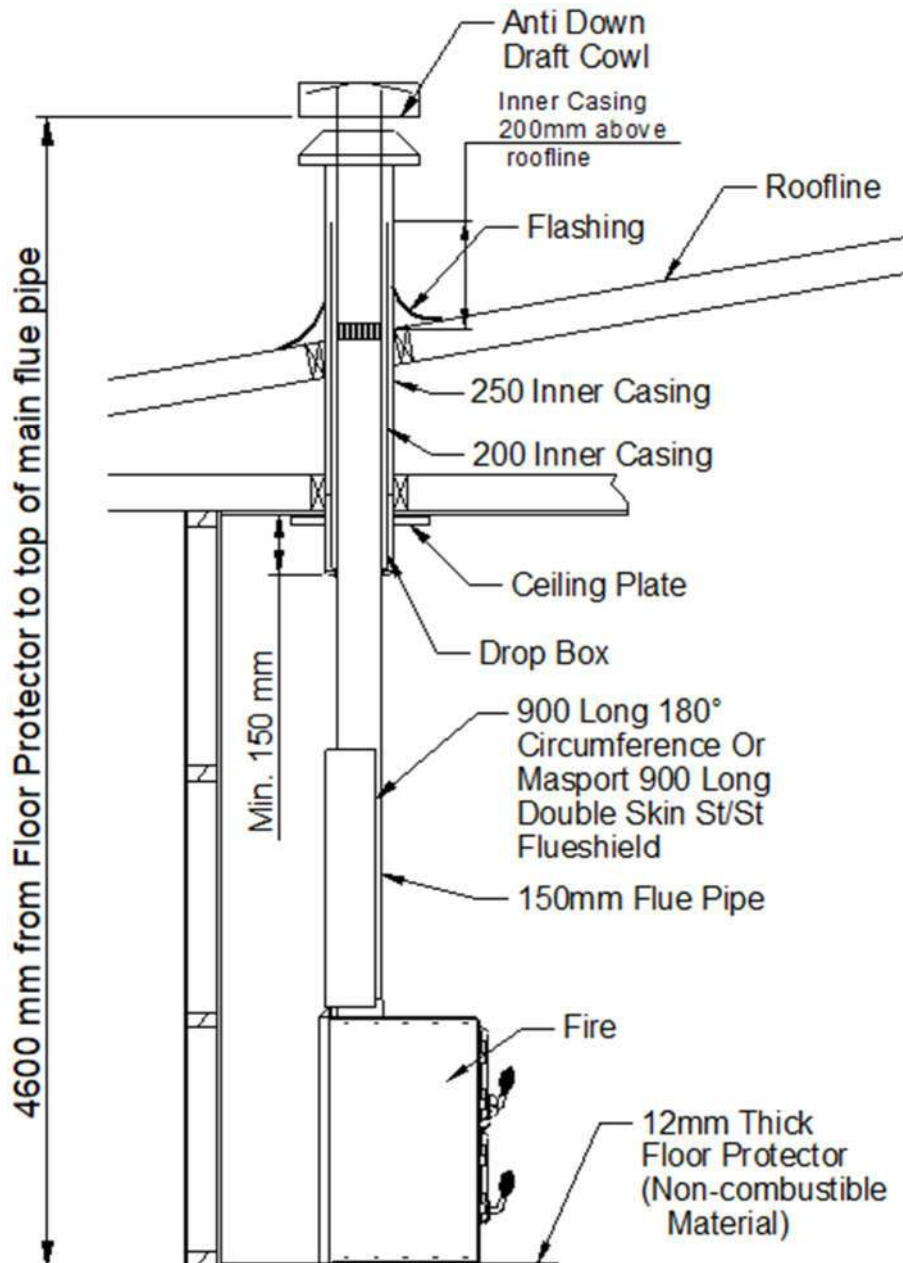

IMPORTANT NOTES

WARNINGS:-

- DO NOT USE FLAMMABLE LIQUIDS OR AEROSOLS TO START OR REKINDLE THE FIRE.
- DO NOT USE FLAMMABLE LIQUIDS OR AEROSOLS IN THE VICINITY OF THIS APPLIANCE WHEN IT IS OPERATING.
- DO NOT STORE FUEL WITHIN APPLIANCE INSTALLATION CLEARANCES.
- OPEN AIR CONTROL (AND DAMPER WHERE FITTED) BEFORE OPENING FIREBOX DOOR.
- THE APPLIANCE AND FLUE-SYSTEM SHALL BE INSTALLED IN ACCORDANCE WITH AS/NZS 2918 AND THE APPROPRIATE REQUIREMENTS OF THE RELEVANT BUILDING CODE OR CODES.

RECOMMENDED FUEL:-

Use any dry hardwood that has been seasoned for at least 12 months. All fuel should be stored with protection from the weather to minimise any potential moisture content.

FLUE FIRE:-

In the event of a chimney fire, close the primary air spindle control to suffocate the fire.

WHERE A WATER JACKET IS FITTED:-

Wetbacks for baker's oven are made of boiler grade stainless steel and are factory fitted. Wetback models of the baker's oven should be installed in accordance with AS3500.4.1 or NZS 4603 and the appropriate requirements of the relevant building code or codes.

Wetback model must only be fitted to open vented hot water systems. Please note that fitting to a mains pressure system is extremely dangerous and could lead to an explosion. Installation of wetback pipework must only be carried out by a registered plumber and the appropriate requirements of all relevant building codes and best practices. Refer the following guidelines for connecting wetback models different hot water systems.

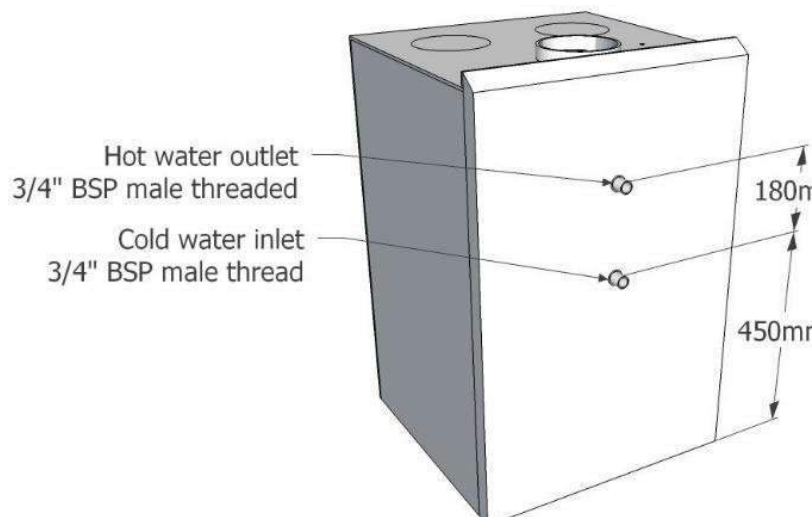
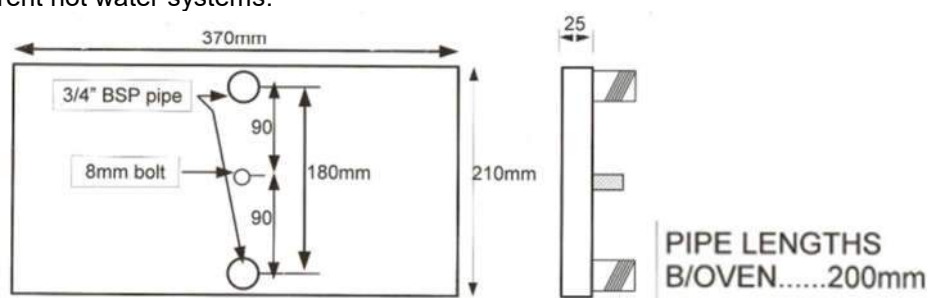

Guidelines for low-pressure hot water systems header tank (open vented)

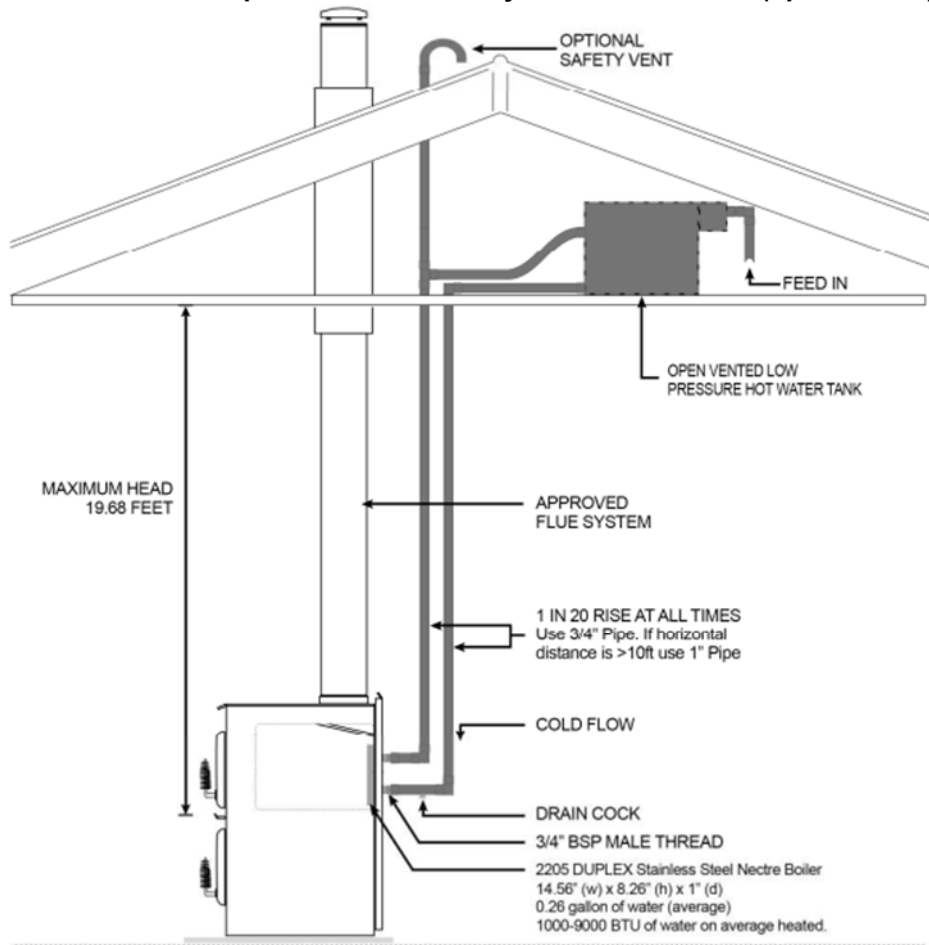

Guidelines for low-pressure hot water systems low level (open vented)

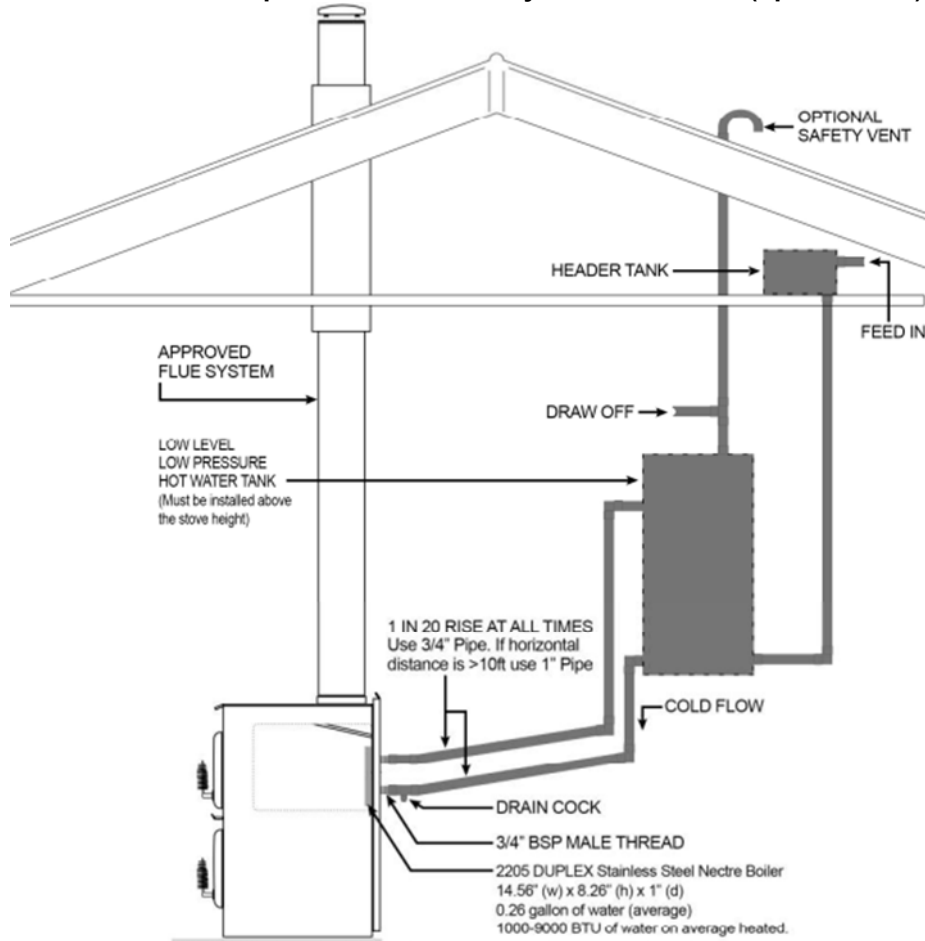

OTHER NOTES:-

- The first time the fire is lit, the appliance will give off some fumes while the paint cures.
- The surfaces of this appliance get hot when the fire has been lit. Please ensure that children, the elderly, and the infirm are made aware of this.
- Never burn woods containing paint, glue, or any other chemical treatments.
- Do not use the fire as an incinerator only burn appropriately seasoned wood.
- Do not overload the appliance with wood.
- Do not operate the stove with the firebox door open.
- Do not operate the appliance with a cracked glass.
- This appliance should be maintained and operated at all times in accordance with these instructions.
- Mixing of appliance or flue-system components from different sources or modifying the dimensional specification of the components may result in hazardous conditions. Where such action is considered, the manufacturer should be consulted in the first instance.

OPERATING INSTRUCTIONS

The Nectre Baker's Oven has the firebox at the top and the oven below. Heat is directed around the oven by closing the damper located next to the flue outlet on top of the stove. The damper is closed when the lever is in the up position.

Necessary air for combustion is provided via two air controls. Primary air is provided via an adjustable spindle located on the front of the firebox door, while secondary air enters via an inlet at the top of the door allowing the air to 'wash' over the glass door keeping it free from sooty deposits.

Before lighting your Baker's Oven, ensure that the damper control is open (the control lever is in the down position).

This appliance has been developed to burn wood only. Burn only dry, well-seasoned firewood which has been cut, split and stacked for at least 12 months, with free air movement allowing it to dry out. Burning wet or unseasoned wood will create tar deposits in the stove and chimney/flue and will not produce a satisfactory heat output. In NZ, radiata pine or macrocarpa is the most commonly available softwood species that are suitable for firewood. Other hardwood species like eucalyptus (bluegum) can also be mixed with softwood to achieve longer burns.

LIGHTING THE STOVE

- To light the stove, first, make sure that the damper is open (down position), and the primary air spindle control on the firebox door is fully open.
- Light a fire using finely chopped wood and establish it so that it has plenty of flames. As soon as the fire is going briskly, close the damper. This directs the flames and flue gases down the sides and around the oven.
- Keep the fire burning briskly until the oven is up to temperature. NOTE: the temperature gauge on the oven door is only a guide to the temperature in the oven. We have found that when the gauge is reading around 100°C, the internal oven temperature is more like 180°C. It is a good idea to use a meat thermometer when cooking.
- To add more fuel to the fire, it is advisable to open the damper (down position) before opening the door. When the firebox is loaded and the door shut, then close the damper (up position). This will avoid having smoke come into the room.

OPERATION WHEN COOKING:-

Always have a brisk fire using small pieces of wood that provide plenty of flames. This type of fire will maintain an oven temperature. The hot plates may be removed using the hot-plate tool provided to enable wok-style cooking directly on the fire.

OPERATION WHEN HEATING:-

1. Increase Heat Output

To increase the heat output from the fire, use larger pieces of wood, ensure the damper is in closed (up position) and use the spindle tool to open the primary air inlet until the level of burning is reached.

With the primary air spindle fully open, the fire will burn very hot, but the wood won't last long. For a longer burn time, reduce the amount of primary air by partially closing the air spindle. The oven may become too hot if run in this mode continually.

2. Background heating with more extended Burn Time

For background heating and increased burn time, use larger pieces of wood, ensure the damper is closed and using the spindle tool to close the primary air inlet. In this mode, the wood will burn for extended periods; however, the oven temperature will drop.

MAINTENANCE

No unauthorised modification of this appliance should be carried out.

1. Removing the Ashes – Depending on the type of wood burned, the ashes will need removing every 2 to 6 weeks. With a small shovel, push the hot coals to one side and shovel most of the ash into a metal bucket. Leave a minimum 10mm thick bed of ash in the bottom of the firebox, allowing the fire to operate at its optimum. Inside the oven is a removable base plate. This plate should be lifted out and any soot underneath removed.
2. Cleaning Paintwork and Glass – The stove, when cold, can be cleaned with a damp cloth. Over the years, the black will fade and can be touched up with high-temperature stove paint. A good hot fire will burn away any deposits left on the glass because of a long slow burn. A dampened newspaper with ash or a non-caustic oven cleaner can be used to clean the glass. It is not advisable to use a cleaner that contains caustic chemicals and abrasive cleaners. The hot plates can also be removed for cleaning.
3. Secondary Air Inlet – A metal strip at the top of the firebox door can be adjusted in and out with the Allen key provided. The strip should be set, leaving a gap of 1mm between the edge of the strip and the front of the Baker's Oven. This gap provides secondary air supply.
4. Door Seal – The door seal is a 13mm round fiberglass braided rope. If it detaches from the groove in the door or needs to be replaced, it can be fixed using silicone.
5. Fire Bricks – In normal use, these can last for many years. It is possible, however, to crack them if logs are continually jammed against them or if frequently struck with a poker. Check periodically for severely broken firebricks, which can be replaced with new ones available from your dealer.
6. Firebox Side Shields – The inner sides of the firebox are protected by 8mm thick steel sheets. Over time these can burn through. In such an event, new ones can be sourced from your dealer and re-hung inside the firebox.
7. Chimney Cleaning – The frequency with which the chimney will need cleaning will depend on the way that the stove has been used, as well as the type and dryness of the wood burned. Keep an eye on the flue passages, and if there appears to be a build-up of soot, it is time to clean the flue.

REPLACEABLE COMPONENTS OF THE APPLIANCE

1. Firebricks: (3) x 234mm x 118mm x 40mm
2. Glass Seal: 1080mm x 8mm x 3mm
3. Glass: 333mm x 195mm x 5mm Pyro Ceramic
4. Door Rope: 900mm x 13mm round
5. Firebox side shields: 8mm thick steel

Bakers Oven - Technical Specifications

Nectre Bakers Oven model have been tested & complies to New Zealand National Environmental Safety Test Standard - AS/NZS 2918:2001			
Overall Dimensions		550mm Wide x 572 mm Deep x 825mm High	
Weight		170 kg	
Bakers Oven is a cooking appliance. Consult your local council for clarification on rules appertaining to the installation of wood-fired cooking appliances/			
Approx. Heating Capacity		Small to Medium Homes (2-3 bedrooms)	
Flue Shield		900mm Long 180 ^o circumference or 900mm long Masport Stainless Steel Double Flue Shield	
Flue System		Standard 4.2M Long, 150mm Masport Flue System with a dropbox or flue system with dropbox that has been tested and comply with ASNZS 2918:2001 Appendix F.	
Floor Protector Requirement		Minimum 12mm thick Floor Protector made of <ul style="list-style-type: none"> - 12mm non-combustible fiber cement board or - Combination of 6mm tile underlay & 8mm tiles 	
Clearances to Combustibles			
Parallel Installation		Corner Installation	
A- Rear Panel to Rear Wall	125 mm	C- Glass to Floor Protector Front	300 mm
B- Cooktop Edge to Side Wall	350 mm	E- Cooktop Corner to Wall	350 mm
C- Glass to Floor Protector Front	300 mm	H- Flue Centre to Wall	640 mm
D- Floor Protector Side	100 mm	L- Floor Protector Diagonal	1618 mm
F- Flue Centre to Rear Wall	260 mm	M- Floor Protector Side	1303 mm
G- Flue Centre to Side Wall	625 mm	N- Flue Centre to Floor Protector Front	713 mm
I- Floor Protector Front Edge	450 mm	R- Flue Centre to Wall Corner	905 mm
J- Floor Protector Width	750 mm	WW- Overall Width of Fire	550 mm
K- Floor Protector Depth	973 mm	DD- Overall Depth of Fire	572 mm
		HH- Overall Height of Fire	825 mm

Seismic Restraint - In New Zealand, it is required that the wood burner and floor protector are secured to prevent shifting in the event of an earthquake. This is best done by fastening the wood burner right through the protector to the floor, using 8mm DynaBolts or 8mm coach screws or equivalent toggle fasteners for wooden floors of appropriate lengths. Seismic holes are at the rear of the burner.

Standard 4.2m Long, 150mm Masport Flue System with Dropbox
 The Masport flue system has been tested and complies to AS/NZS 2918:2001 Appendix F.

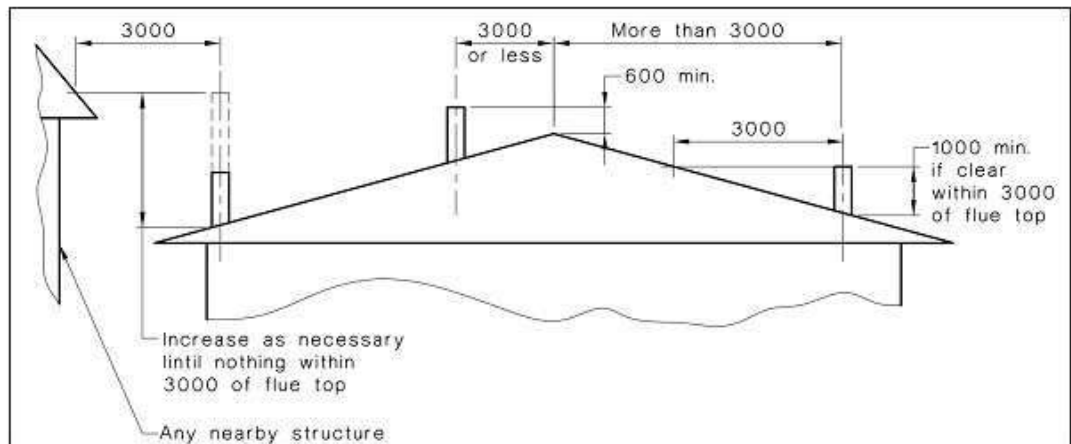
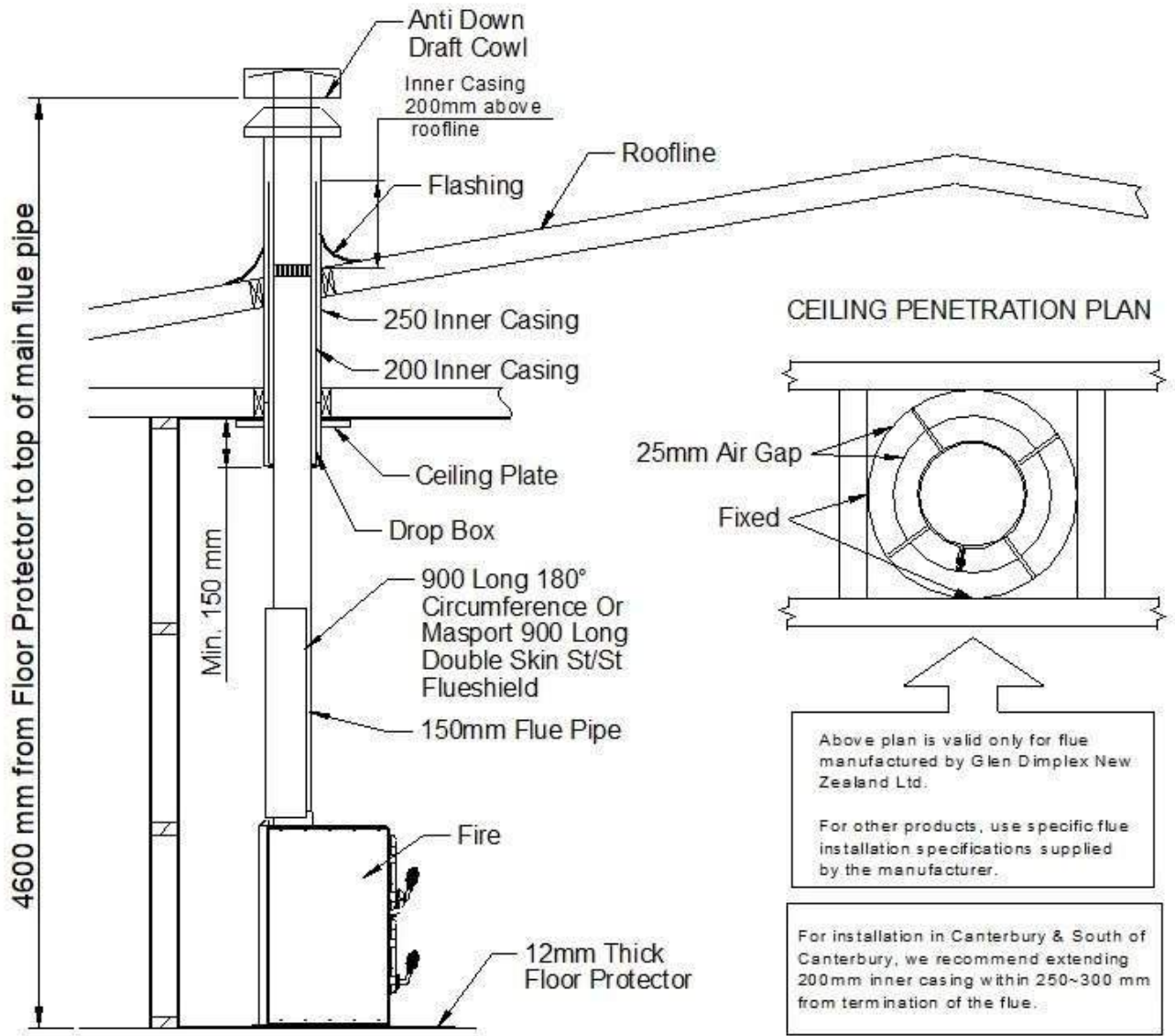

If a flue exits out of the roof within 3 meters from the ridge, the outer shield height shall be not less than 600mm above the ridge. If the flue exits further than 3 meters out from the roofridge then it must project at least 1000mm above roof penetration. This dimension may need increased to ensure that the top of the flue is at least 3 meters away from the roof or other obstructions when measured horizontally.

The flue pipe shall extend not less than 4.6m above the top of the floor protector. Due to factors such as roof pitch, predominant winds, nearby obstructions (ie. trees, buildings), and fire placement, flue lengths and hats/cowls may vary.

Cut Here

GLEN DIMPLEX WARRANTY REGISTRATION **BAKER'S OVEN**

Thank you for purchasing a Nectre appliance. We ask you to complete the following information and return to the Glen Dimplex Warranty Registration Department on the following address:

New Zealand : P O Box 58473, Botany, Manukau 2163, Auckland
Australia : Unit 1, 21 Lionel Road, Mount Waverley, Victoria 3149

Mr/Mrs/Miss/Ms Name: _____

Address: _____

_____ Post Code: _____

Telephone: _____ Fax: _____

Email: _____

Model: _____ Serial Number: _____

Retailer: _____ Purchase Date: _____

Price: _____

Installed By: _____ Date Installed: _____

We at Glen Dimplex strive to provide you with quality products and have a continuous product development program. To help achieve our objectives to our mutual benefit we would welcome your feedback on the following questionnaire.

Cut Here

Question	Please tick appropriate remark			
1. General presentation of Product	<input type="checkbox"/> Excellent	<input type="checkbox"/> Good	<input type="checkbox"/> Ok	<input type="checkbox"/> Needs to Improve
2. Styling and Looks	<input type="checkbox"/> Excellent	<input type="checkbox"/> Good	<input type="checkbox"/> Ok	<input type="checkbox"/> Needs to Improve
3. Packaging	<input type="checkbox"/> Excellent	<input type="checkbox"/> Good	<input type="checkbox"/> Ok	<input type="checkbox"/> Needs to Improve
4. Is documentation easy to follow and informative?	<input type="checkbox"/> Excellent	<input type="checkbox"/> Good	<input type="checkbox"/> Ok	<input type="checkbox"/> Needs to Improve
5. Fixtures & Fittings (Loose parts)	<input type="checkbox"/> In order	<input type="checkbox"/> Items missing	<input type="checkbox"/> Needs to Improve	
6. Do you currently own Masport, Nectre or Dimplex product?	<input type="checkbox"/> Yes	<input type="checkbox"/> No	Which? -	
7. Why did you decide on Nectre? (tick one or more options)	<input type="checkbox"/> Knew this brand		<input type="checkbox"/> Suggested by Friend	
	<input type="checkbox"/> Dealer recommended		<input type="checkbox"/> Better Price	
	<input type="checkbox"/> Performance		<input type="checkbox"/> Features	
8. Other Comments	_____			

Privacy Act Notice: the owner named on the Warranty Registration consents and agrees that Glen Dimplex may retain and use the information in this warranty card, including details about the owner for marketing and development purposes. The owner also agrees that Glen Dimplex may also share purposes with [intended recipients of such information]. In accordance with the New Zealand Privacy Act 1993 and the Australian Privacy Act 1988, the owner shall have the right to request the correction of, as well as inspect, all personal information held by Glen Dimplex on that owner.

**Please cut & mail this completed form within 30 days of installation to your
Glen Dimplex Warranty Registration Department at the above address**

Cut Here



WARRANTY FOR NECTRE BAKER'S OVEN

This warranty is provided in New Zealand by Glen Dimplex New Zealand Ltd and in Australia by Glen Dimplex Australia Pty Ltd. (together referred as "Glen Dimplex")

This warranty is provided to the first domestic purchaser of a Nectre N65 Low Emission Burner. It applies from the date of purchase from or through an authorized Nectre Fire Distributor in relation to each product or component for the period below.

TYPE OF PART	WARRANTY (In Years)	
	PARTS	LABOUR
BURNER's STEEL FIRE BOX	10	5
DOOR GLASS & SEAL	1	1
FIRE BRICKS / BOARDS & RETAINERS	1	1
BAFFLE SYSTEM & AIR TUBES	1	1
GLEN DIMPLEX FLUE SYSTEM	1	1

During the warranty period, Glen Dimplex will repair or replace (at its option) any Nectre Wood Fire which is found to be defective in materials or workmanship. Repairs will be carried out by an approved Nectre Heating Service Agent.

What is covered under this warranty?

- Repair or replacement of parts
- Labor costs relating to the Wood Burner
- Reasonable transport or travel costs.

Consumers may have additional rights under the Consumer Guarantees Act 1993 (New Zealand) or the Australian Trade Practices Act 1974 including the Australian Consumer Law.

Conditions

This warranty does not apply and will be void where:

- The Wood Burner is not installed in accordance with AS/NZS2918/:2001 or any building code or consent;
- The Wood Burner is not installed by a qualified specialist installer;
- Any electrical work has not been carried out by a Registered Electrician;
- The Wood Burner has been moved and reinstalled, or has been modified in a manner that is not consistent with the Installation Guide or the Owner's Manual;
- The Wood Burner has not been installed, operated, or maintained according to the Installation and Operations Manual;
- The Wood Burner is acquired for business use in any way.

What is not covered?

- Wear and tear, including wear and tear through normal use on Multi-fuel fire grates and cast-iron firebox liners.
- Labor costs relating exclusively to components not manufactured by Glen Dimplex.
- Damage caused by incorrect use or the burning of treated or painted wood, driftwood or other fuels which are not recommended;
- Travel costs for a distance greater than 50 km from the nearest approved Nectre Heating Service Agent. (The location of the Wood Fire must be advised to Glen Dimplex or its sales agents at the time of purchase or using warranty registration form)
- Defects, malfunctions, or failures caused by incorrect installation, poor installation, normal wear and tear, misuse, neglect, accidental damage, or failure to follow operating instructions in the Owner's Manual (including fuel selection, product operation and maintenance instructions), repairs or modifications by persons not authorised by Glen Dimplex, use of parts not supplied by Glen Dimplex, or damage or other events which have occurred since the product left the control of Glen Dimplex.
- Direct, indirect, or consequential losses or special damages of any kind (including costs of collection and delivery) other than repair or replacement of products or components under this warranty, where any goods are acquired or used for the purposes of a business;

How to obtain warranty service?

- Completed Warranty registration form (previous page) needs to be mailed within 30 days of installation to your Glen Dimplex Warranty Registration Department.
- Warranty Claims must be made at the place of purchase.
- Reasonable proof of purchase date is required to make a warranty claim. You should keep your purchase receipt.
- Warranty repair will be completed according to the normal work practices of the service agent.
- Make the faulty part(s) available to Glen Dimplex for inspection so that the validity of the claim can be established by them.

Manufactured in New Zealand by:

GLEN DIMPLEX NEW ZEALAND LTD

NZ Registration No – 1506305

P.O. Box 58473, Botany,
Manukau, Auckland 2163

Phone: 0800 666 2824

Fax : 09 274 8472

Email : sales@glendimplex.co.nz

Web : www.nectre.co.nz

*Glen Dimplex New Zealand Ltd reserves the right to change specifications, the content of this manual or the design of its product without prior notice.